



PPE Inspection form

How to inspect your pulleys.

Owner:

Model:

Serial #:

Date of inspection:

Date of first use:

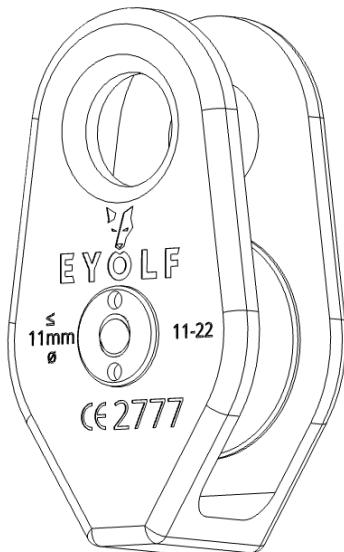

If there is any doubt or failure, the harness should not be used.

Visual check of the safety components:

- Readable markings present?
- Check body, side plates, eyes (wear, burrs, corrosion, cracks, dents, bends, deformation)
- Check sheave (wear, burrs, corrosion, cracks, dents, bends, deformation)
- Check friction components (grooves in pulley wheel, area where rope rubs)
- Check lateral movement (as when produced)
- Check rivets, bolts and other fasteners (loose, wear, burrs, corrosion, cracks, deformation)
- Check condition of other components (plastic parts, rubber handle, pullers, etc.)

Operational check

- Check bearing (must run freely, maintain if needed)
- Check closing of the moving sidepiece (must run freely, maintain if needed)
- Check rotating eyes (must run freely, maintain if needed)
- Check device on rope for correct function

In Service:

Yes No

Comments: